



## Programmable Unicable II cascadable switch with up to 32 User Bands with Terrestrial input & 1 Legacy port

(AC/DC power adapter and power inserter)

Model: IDLU-UST110-CUO10-32P

Item: 5151



The IDLU-UST110-CUO10-32P is a small form factor Unicable2 multiswitch enabling installations with up to 32 satellite receivers over a single cable based on digital channel stacking technology. Digital channel stacking technology applies digital signal processing after wideband Analog to Digital converters (full band capture) to select and reorder transponder channels. Compared with analog channel stacking, which is based on analog frequency translation to fixed frequency slots, the digital channel stacking implementation removes the need of in-band SAW filters, offers a full flexibility of channel selection, supports many more set top boxes through a single coax cable, greatly simplifies installations at subscribers homes all at much lower cost and lower power consumption.

Controlled by the connected receivers over EN50494 or EN50607 protocol, the multiswitch will select the desired transponder channel, convert its frequency to the respective User Band frequency and stack it over the Unicable output ports through Digital to Analog converter (also known as 'Dynamic' mode).

The multiswitch firmware can be configured to deliver a fixed transponder-to-IF frequency mapping (also known as 'Static' mode) and line up to 32 transponders (depending on the bandwidth of the desired transponders) over the Unicable output ports. This allows for an unlimited number of receivers to be connected to the switch making MDU installations substantially cheaper and simpler than ever before. The operation mode - dynamic or static - output power level, channel bandwidth, UB numbers, center frequencies and the functionality of each of the output ports can all be programmed as well.

The multiswitch receives (and cascades) 4 satellite IF bands/polarities (LV, LH, HV and HH) and Terrestrial VHF/UHF signals. Both Unicable and Legacy output ports combines the Terrestrial signal. The Terrestrial signal is not amplified. The multiswitch is powered over the supplied AC/DC adapter and power inserter device allowing greater flexibility in various installation scenarios. The communication protocol between the multiswitch unit and the connected receivers is based on EN50494 and/or EN50607 and can be defined per User Band allowing operators to support installations consisting of both EN50494-only and EN50607 compatible Next Generation PVRs and HGWs.

For Indoor and outdoor installations.

\* Programmer not included, sold separately as an optional accessory.

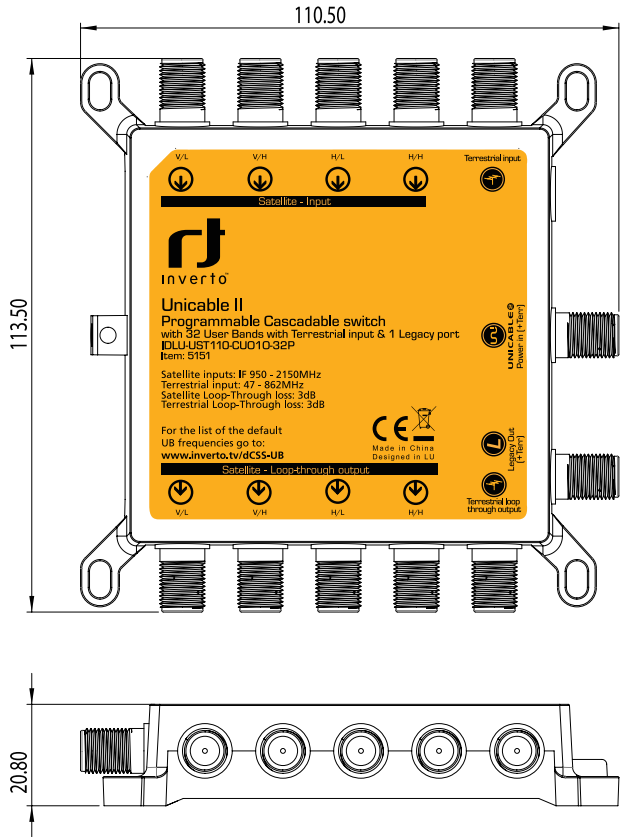

### 32 User Band Unicable multiswitch with Legacy port Connection Diagram

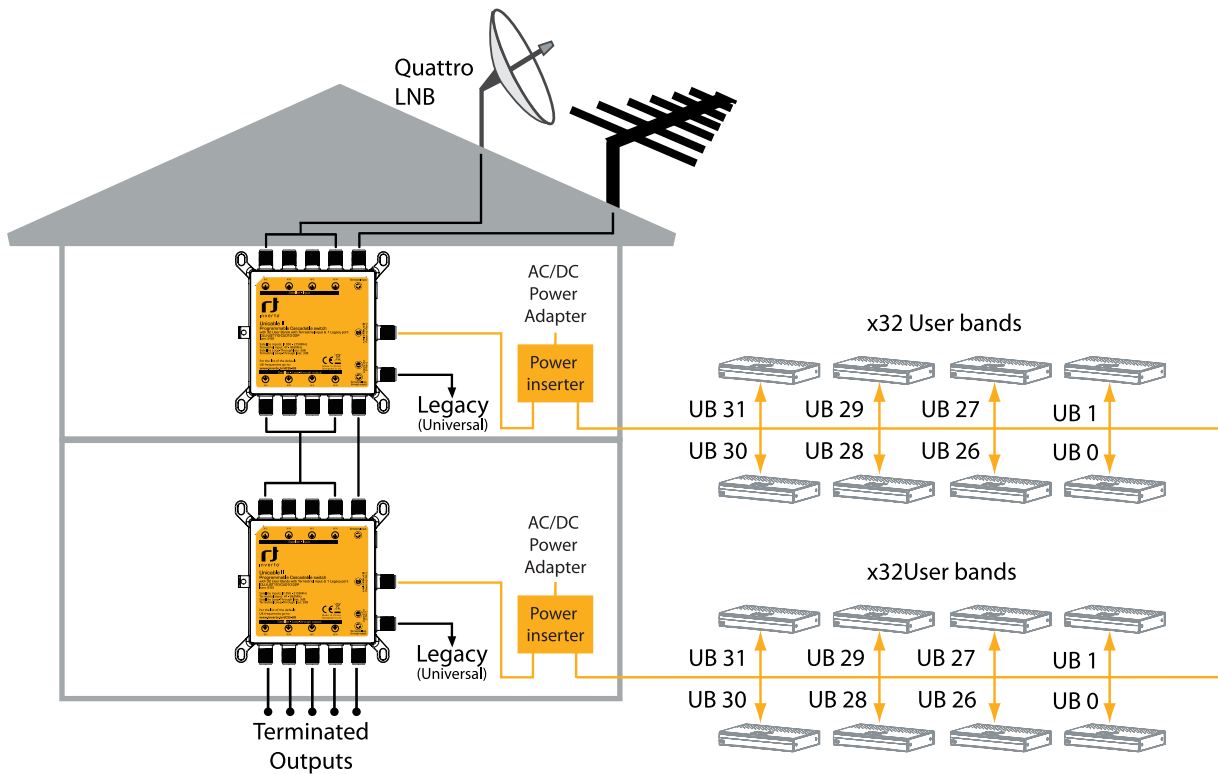

Supplied with AC/DC power adapter and power inserter

# Technical Specifications

Inputs	4 x Satellite IF inputs from Quattro LNB 1 x UHF/VHF input from Terrestrial antenna
Outputs	4 x loopthrough satellite IF outputs 1 x loopthrough terrestrial output 1 x Legacy output with combined terrestrial signal. 1 x Unicable output with up to 32 User Bands with combined terrestrial signal
Control Protocol	DiSEqC1.x/DiSEqC2.0, EN50494/EN50607
Inputs frequency range: Satellite	950 ~ 2150 MHz
Terrestrial	47 ~ 862 MHz
Loop-through loss: Satellite	3 dB max.
Terrestrial	3 dB max.
Conversion gain: Unicable output	25dB min
Legacy universal output	-1 to +7 dB
Output signal level (AGC controlled)	Configurable (default -25dBm)
Input power range	-50 to -15 dBm
User band (Channel) bandwidth	Configurable, 10~80MHz (default 30MHz)
User band (Channel) gain ripple	3 dB max.
User band frequencies (Channels)	Configurable; Default 32 User bands: CH0: 1210MHz (EN50494+EN50607) CH16: 1530MHz (EN50607) CH1: 1420MHz (EN50494+EN50607) CH17: 1566MHz (EN50607) CH2: 1680MHz (EN50494+EN50607) CH18: 1602MHz (EN50607) CH3: 2040MHz (EN50494+EN50607) CH19: 1638MHz (EN50607) CH4: 984MHz (EN50494+EN50607) CH20: 1716MHz (EN50607) CH5: 1020MHz (EN50494+EN50607) CH21: 1752MHz (EN50607) CH6: 1056MHz (EN50494+EN50607) CH22: 1788MHz (EN50607) CH7: 1092MHz (EN50494+EN50607) CH23: 1824MHz (EN50607) CH8: 1128MHz (EN50607) CH24: 1860MHz (EN50607) CH9: 1164MHz (EN50607) CH25: 1896MHz (EN50607) CH10: 1256MHz (EN50607) CH26: 1932MHz (EN50607) CH11: 1292MHz (EN50607) CH27: 1968MHz (EN50607) CH12: 1328MHz (EN50607) CH28: 2004MHz (EN50607) CH13: 1364MHz (EN50607) CH29: 2076MHz (EN50607) CH14: 1458MHz (EN50607) CH30: 2112MHz (EN50607) CH15: 1494MHz (EN50607) CH31: 2148MHz (EN50607)
RF Isolation:	
Satellite/Satellite IF	28 dB min.
Satellite/Terrestrial	28 dB min.
Satellite Channel/Channel (UBs)	28 dB min.
LO phase noise	@1 KHz: -80 max dBc/Hz @10 KHz: -92 max dBc/Hz @100 KHz: -96 max dBc/Hz @1 MHz: -104 max dBc/Hz
Integrated phase noise	1.5 degrees max.
Input / Output VSWR	2.5 : 1
Input / Output Impedance	75 Ω (F-Type)
Legacy port switching	V/L=>13V/0kHz , V/H=>13V/22kHz H/L=>18V/0kHz , H/H>18V/22kHz
LNB power supply	13/18V, max 300mA
DC Power consumption	450mA @13Vdc [max.]
Working Temperature	- 20 ~ + 60 °C
Dimensions	113.50 x 110.50 x 20.80(H x W x D) mm

For purpose of brevity, some product descriptions in this sheet remain at platform level and may not be referred to as detailed datasheets of the products. Inverto Digital Labs reserves the right to amend, omit or add products, product-lines, and / or features without notice. As product specifications may change without notice, always contact Inverto to obtain the latest product specification sheets.

For further details contact: [sales@inverto.tv](mailto:sales@inverto.tv)

FTA Communication Technologies S.a.r.l Tel. +352 264 367 1 Fax. +352 264 313 68



[www.inverto.tv](http://www.inverto.tv)