

Click object to rotate

Eco

Quattro Eco 40mm LNB
IDLB-QUTL40-OOECO-OPP
Item: 3410



This Universal Quad LNB was specifically designed to meet the latest requirements in the European satellite markets. It features low power consumption and provides optimized reception capabilities to support the growing market of satellite HD-transmissions market across Europe. It enables the reception of satellite signals from one satellite and its distribution to maximum four Set Top Boxes with Single Tuner (or two STBs with Twin Tuner). It provides an excellent Noise Figure and Phase Noise performance and is ready for High Definition transmissions. Designed to meet strict specifications and manufactured to the highest industry quality standards, this LNB is an ideal solution for satellite broadcast reception across Europe.

Main Features:

- Low phase Noise, DVB-S2 (HDTV) compliant
- Ultra Low Noise Technology ULN+
- Low Power Consumption
- High Cross Polarization Isolation
- High Frequency Stability



Technical data

Low Band Input Frequency Range	10.7 ~ 11.7 GHz
Low Band Output Frequency Range	950 ~ 1950 MHz
Low Band LO Frequency	9.75 GHz
High Band Input Frequency Range	11.7 ~ 12.75 GHz
High Band Output Frequency Range	1100 ~ 2150 MHz
High Band LO Frequency	10.6 GHz
Noise Figure	0.1 dB (ULN+) Typ. (0.7 dB Max.)
LO Initial Accuracy	+/- 1.0 MHz Max.
LO Temperature Drift	+/- 3.0 MHz Max.
Phase Noise (@ 10 kHz)	- 85 dBc / Hz Max.
Conversion Gain	56 dB Min.
Gain Ripple (Over 26 MHz Bandwidth)	+/- 0.75 dB
Gain Variation (Over Full Band)	+/- 4 dB Max.
Image Rejection	40 dB Min.
1 dB Compression Point (@ Output)	0.0 dBm Min.
Cross Polarization Isolation	22 dB Min.
Control Signal Ca (Vertical Polarization)	11.0 ~ 14.0 V
Control Signal Cb (Horizontal Polarization)	16.0 ~ 20.0 V
Control Signal Cc (Band Switching)	22 +/- 4 kHz
Output VSWR	2.5 : 1
In-Band Spurious	- 60 dBm Max.
Current Consumption	100 mA Max. @ 11 ~ 20 V
Operating Temperature	- 30 °C ~ + 60 °C
Output Impedance	75 Ω
Output Connector	F-Type (Female)
Weight	234 g

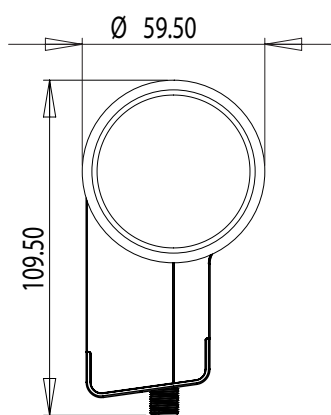
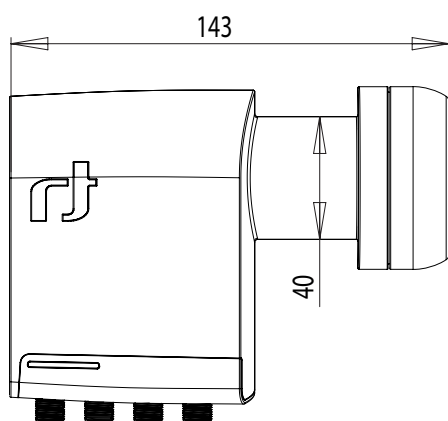

For purpose of brevity, some product descriptions in this sheet remain at platform level and may not be referred to as detailed datasheets of the products. Inverto Digital Labs reserves the right to amend, omit or add products, product-lines, and / or features without notice.

For further details contact: sales@inverto.tv

FTA Communication Technologies S.a r.l Tel. +352 264 367 1 Fax. +352 264 313 68



www.inverto.tv